

Dynapac CC900G

Double drum vibratory rollers



Technical data



Masses

Max. operating mass	2,900 lbs
Operating mass (incl. ROPS)	2,800 lbs
Module mass (front/rear)	1,200 lbs/1,600 lbs



Propulsion

Speed range	0-5 mph
Vertical oscillation	±13°
Theor. gradeability	35 %



Compaction

Centrifugal force	3,800 lb
Nominal amplitude	0.016 in
Static linear load (front/rear)	34 /44 lbs/in
Vibration frequency	4,200 vpm
Water tank	50 gal



Engine

Manufacturer/Model	Honda GX630RH QYD
Type	4-stroke gasoline
Rated power, SAE J1995	19 hp @ 3,000 rpm
Fuel tank capacity	6 gal



Engine

Manufacturer/Model	Loncin LC2V78F-1
Type	4-stroke gasoline
Rated power, SAE J1995	17 hp @ 3,600 rpm



Hydraulic system

Driving	Axial piston pump with variable displacement. 2 radial piston motors with constant displacement.
Vibration	Gear pump/motors with constant displacement.
Steering	Gear pump with constant displacement.
Service brake	Hydrostatic in forward and reverse lever.
Parking/Emergency brake	Failsafe brake in both drums.

Find us locally at www.atlascopco.com

We reserve the right to change specifications without notice. Photos and illustrations do not always show standard versions of machines. The above information is a general description only, all informations are supplied without liability.

Dynapac CC900G

Double drum vibratory rollers

Atlas Copco

Technical data

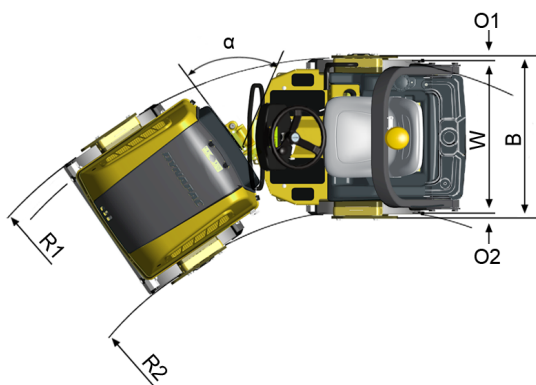
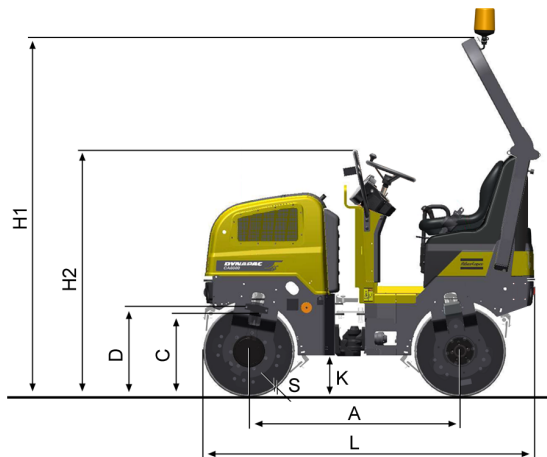

Dimensions

A. Wheelbase	53 in
B. Width	38 in
C. Curb clearance	18 in
D. Drum diameter	23 in
H1. Height, with ROPS/cab	91 in
H2. Height, w/o ROPS/cab	62 in
K. Ground clearance	10 in
L. Length	83 in
O1. Overhang, right	1 in
O2. Overhang, left	1 in
R1. Turning radius, outside	9 ft
R2. Turning radius, inside	6 ft
S. Drum shell thickness	0.4 in
W. Drum width	35 in
α. Steering angle	±34°



Standard equipment

Emergency stop, Horn, Hour meter, Ignition key, Propulsion in both drums, Foldable ROPS (incl. seat belt), Seat safety switch, Sliding operator seat, Towing eyelet (front/rear), Vibration on front drum, Warninglight for brakes, Warning light for hydraulic oil temp

Find us locally at www.atlascopco.com

We reserve the right to change specifications without notice. Photos and illustrations do not always show standard versions of machines. The above information is a general description only, all informations are supplied without liability.

rce_cc900g_us-20160111.093616.pdf 2016-01-11 09:36